

FRONT CONNECTION METHOD

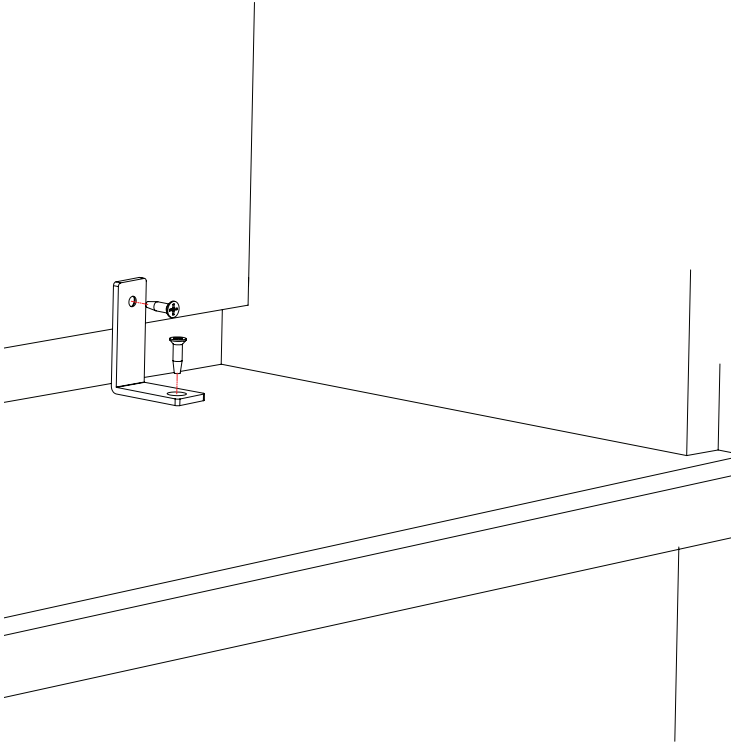

INCLUDED HARDWARE:

- (4) #8 x 5/8" PHILLIPS SCREW [BWT28o]
- (2) 1" x 1 5/8" BLACK ANGLE BRACKET [C15Coo]

BACK CONNECTION METHOD

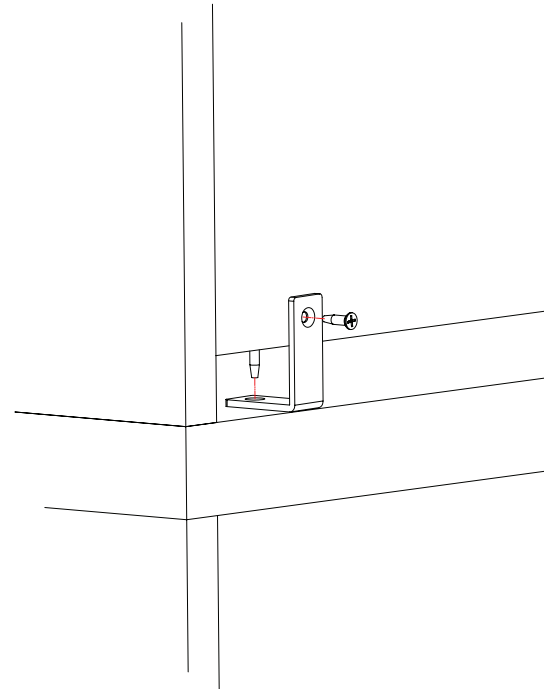

INSTRUCTIONS:

1. Align hutch and worksurface.
 2. Decide between the front or back connection method (see diagram).
 3. Mark and drill the worksurface and hutch for the angled brackets as shown in the diagram. Bracket location may vary.
- Caution:** If paper management trays are used, drill holes to the left or right of where the tray will be located. The paper management trays WILL NOT fit in front of brackets.
4. Install as shown in the diagram.

Jofco

P.O. Box 71 | Jasper, Indiana 47546 | 800-23-JOFCO | www.jofco.com

Instruction Sheet Number: IF00001
Hutch to Worksurface Connection

Effective Date: 12-7-09 CG01

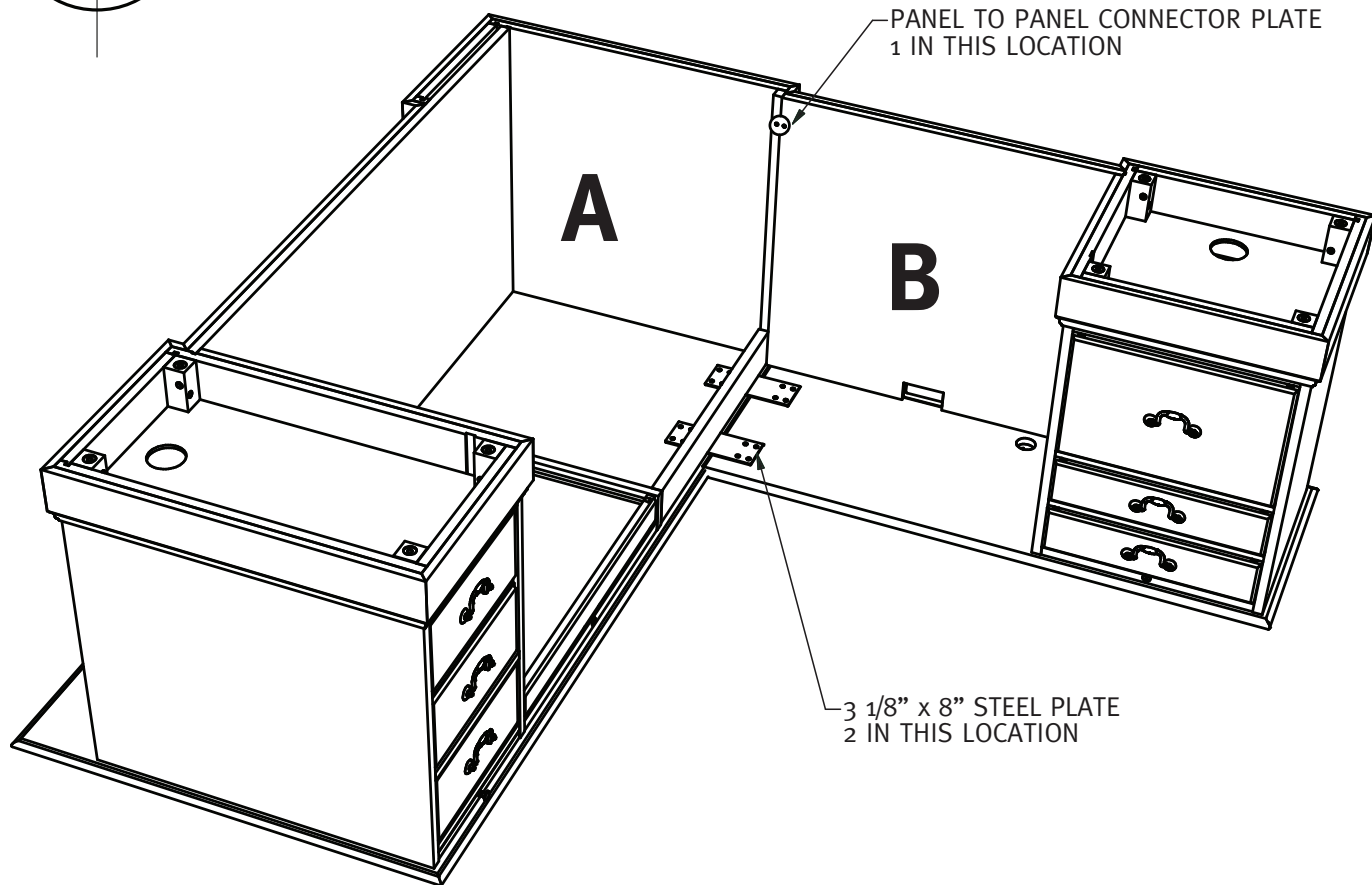
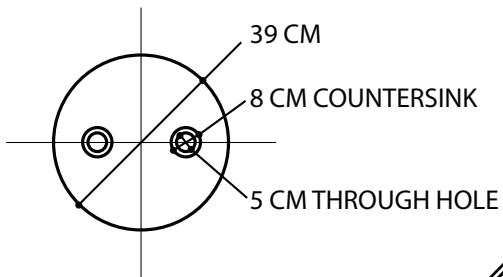

(Personal shelf on desk not shown.)

INSTRUCTIONS:

1. Uncarton the single pedestal desk (Unit A) and place in the desired location.
2. Attached to the underside of the top are two (2) 3 1/8" x 8" steel plates. Unscrew and extend outward so they are protruding half way from under the top. Screw plates into place. Additional screws and a smaller panel to panel connector plate are enclosed for use in attaching the desk and return end panels.
3. Uncarton the desk return (Unit B) and place in position over the extended steel plates. Align unit so the top fits tightly over the desk top and both tops are flush at the side. Hold in place and install screws to underside of the desk return top. **Do not tighten completely.**
4. Install the small metal panel to panel connector plate to the desk end panel just above the shelf. Align the return end panel and base. Tighten as necessary.
5. Place a level across the desk top as well as the return. Level both units by adjusting the floor levelers located in each end panel.
6. After leveling, tighten screws. Be careful not to apply too much pressure.

Jofco

P.O. Box 71 | Jasper, Indiana 47546 | 800-23-JOFCO | www.jofco.com

Instruction Sheet Number: IFTR001

Traditional L-Group Connection

Effective Date: 4-1-08 CG07

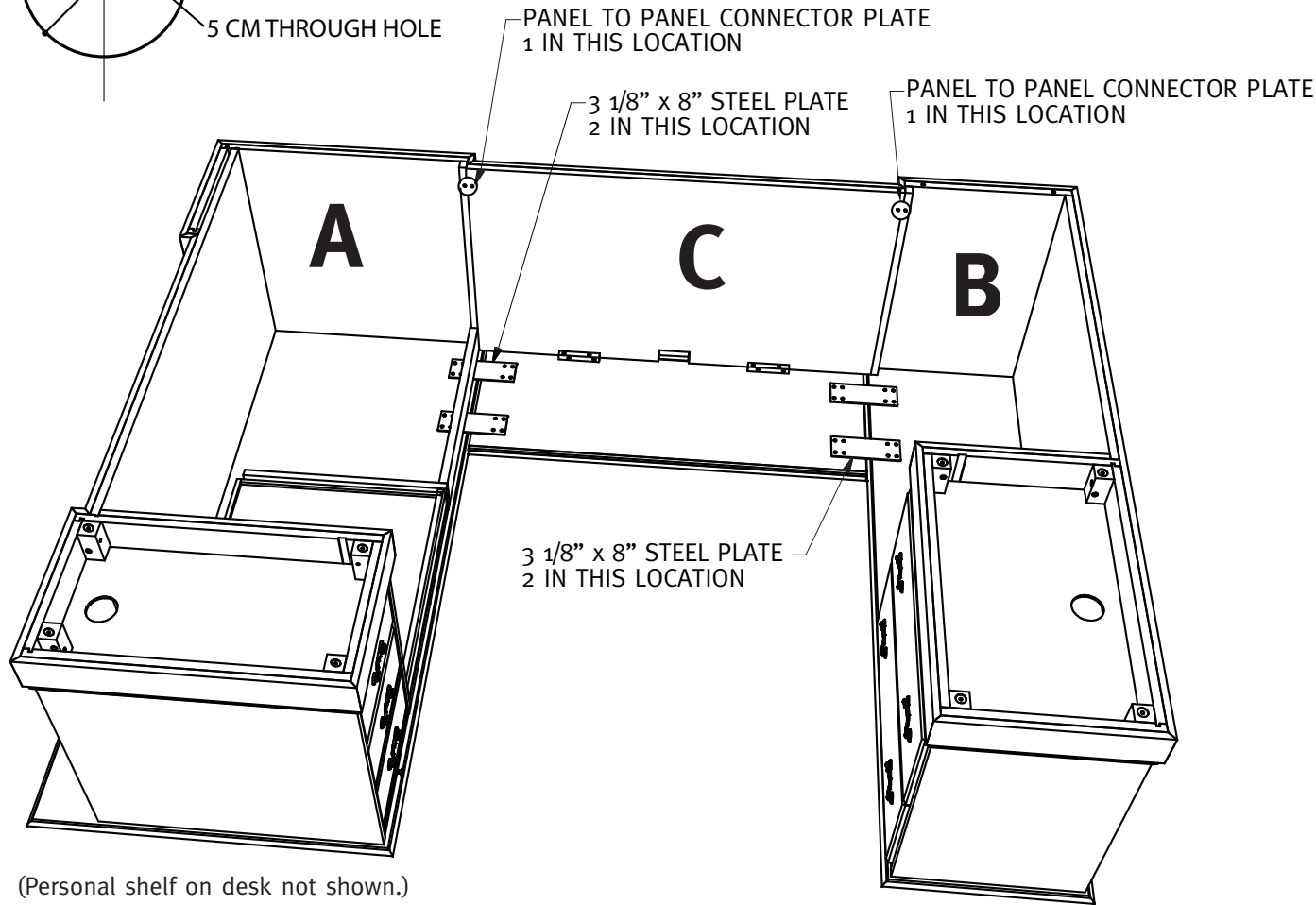
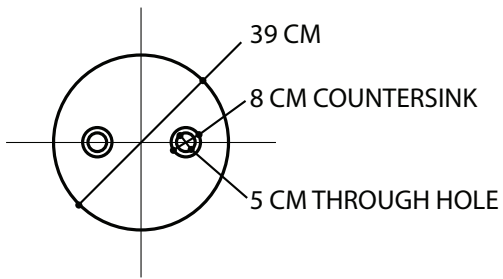

INSTRUCTIONS:

1. Uncarton the single pedestal desk (Unit A) and place in the desired location.
2. Uncarton the credenza (Unit B) and place an adequate distance from the user side of desk to allow for bridge placement.
3. Attached to the underside of both the desk and credenza are two (2) 3 1/8" x 8" steel plates. Unscrew and extend outward so they are protruding half way from under the top. Screw plates into place. Additional screws and two (2) smaller panel to panel connector plates are enclosed to attach the desk and credenza end panels to the bridge modesty panel.
4. Uncarton the two-piece bridge (Unit C). Place the top only on the steel plates that are extending from the other units. Align to desk side for a tight fit and fasten to the plate. Check level of the desk and adjust accordingly. After leveling, align and attach the other side to the credenza. Check for tight and accurate fit of the top connections before tightening screws.
5. Place modesty panel under the bridge top from the user side and align as necessary. Screw the small panel to panel connector plate to the desk end panel just above the shelf and then to the modesty panel. Do the same to the other side, attaching the panel to panel connector small plate to the credenza end first, then the modesty panel. Check vertical alignment of modesty panel to both end panels and then attach to the underside of the top.

Jofco

P.O. Box 71 | Jasper, Indiana 47546 | 800-23-JOFCO | www.jofco.com

Instruction Sheet Number: IFTR002

Traditional U-Group Connection

Effective Date: 4-1-08 CGo8

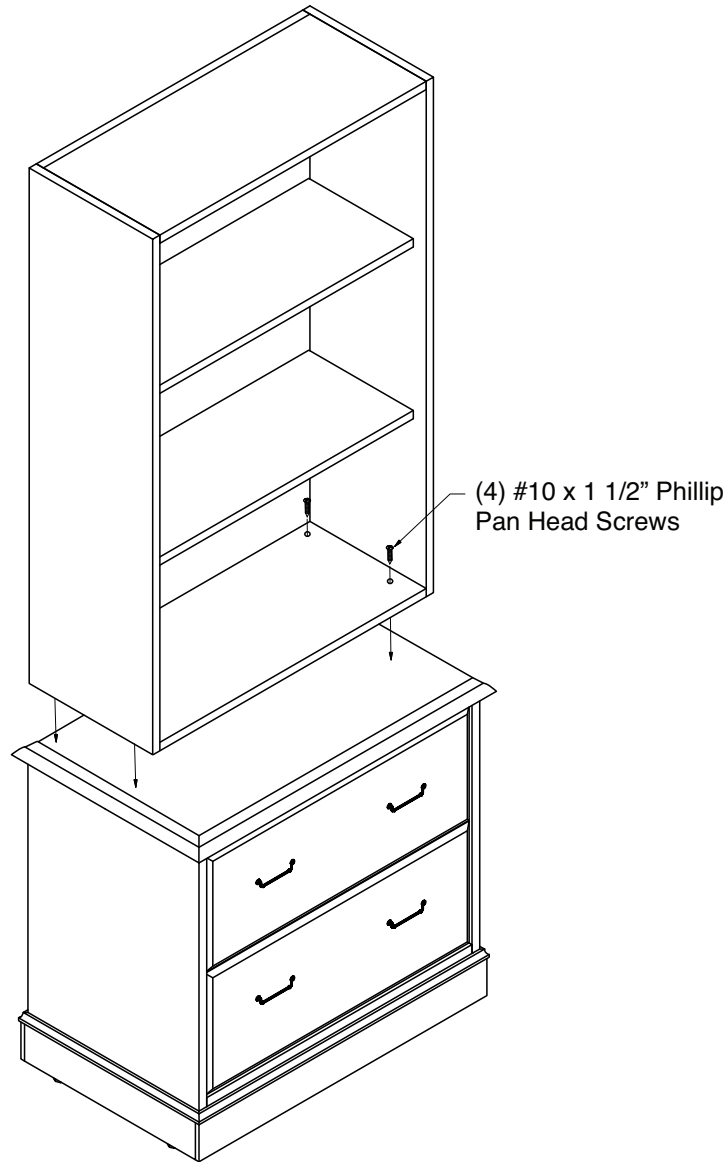

INSTRUCTIONS:

1. Position hutch in desired location on the base unit(s).
2. Screw four (4) #10 x 1½" phillip pan head screws in the pre-drilled holes into the top as shown in Detail A.

Note: Rubber cushions should be used when opting to not fasten the hutch to the base unit according to step two (2).

Illustration is for visual of attachment process only. Units shown may vary from units being installed. This attachment process may be used on the following units:

HU4047NB	HU8047NB
HUWD4047NB	HUWD8047NB
HUDGR4047NB	HUDGR8047NB
HUDGL4047NB	HUDGL8047NB
40HU72	80HU72
40HUWD72	80HUWD72
40HUGR72	80HUGR72
40HUGL72	80HUGL72

Jofco

P.O. Box 71 | Jasper, Indiana 47546 | 800-23-JOFCO | www.jofco.com

Instruction Sheet Number: IFTR003

Traditional Overhead Connection

Effective Date: 9-22-08 CG09