

FRONT CONNECTION METHOD

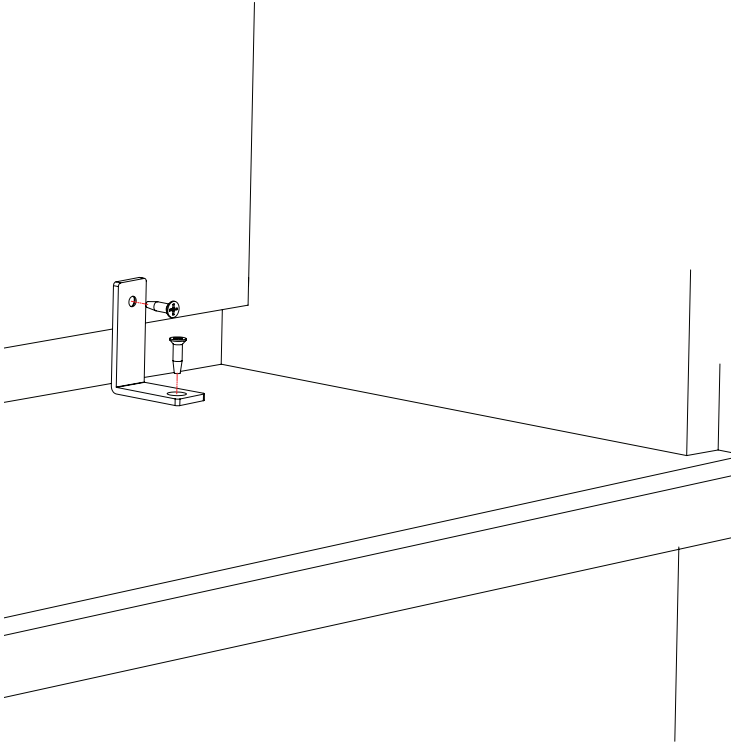

INCLUDED HARDWARE:

- (4) #8 x 5/8" PHILLIPS SCREW [BWT28o]
- (2) 1" x 1 5/8" BLACK ANGLE BRACKET [C15Coo]

BACK CONNECTION METHOD

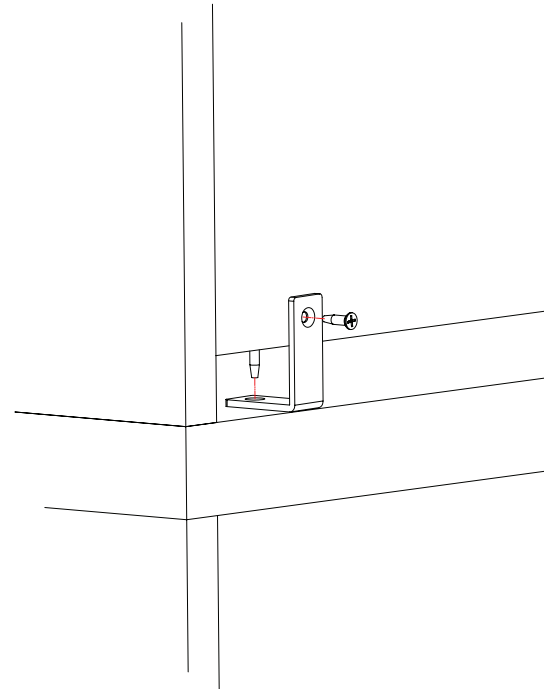

INSTRUCTIONS:

1. Align hutch and worksurface.
 2. Decide between the front or back connection method (see diagram).
 3. Mark and drill the worksurface and hutch for the angled brackets as shown in the diagram. Bracket location may vary.
- Caution:** If paper management trays are used, drill holes to the left or right of where the tray will be located. The paper management trays WILL NOT fit in front of brackets.
4. Install as shown in the diagram.

Jofco

P.O. Box 71 | Jasper, Indiana 47546 | 800-23-JOFCO | www.jofco.com

Instruction Sheet Number: IF00001
Hutch to Worksurface Connection

Effective Date: 12-7-09 CG01

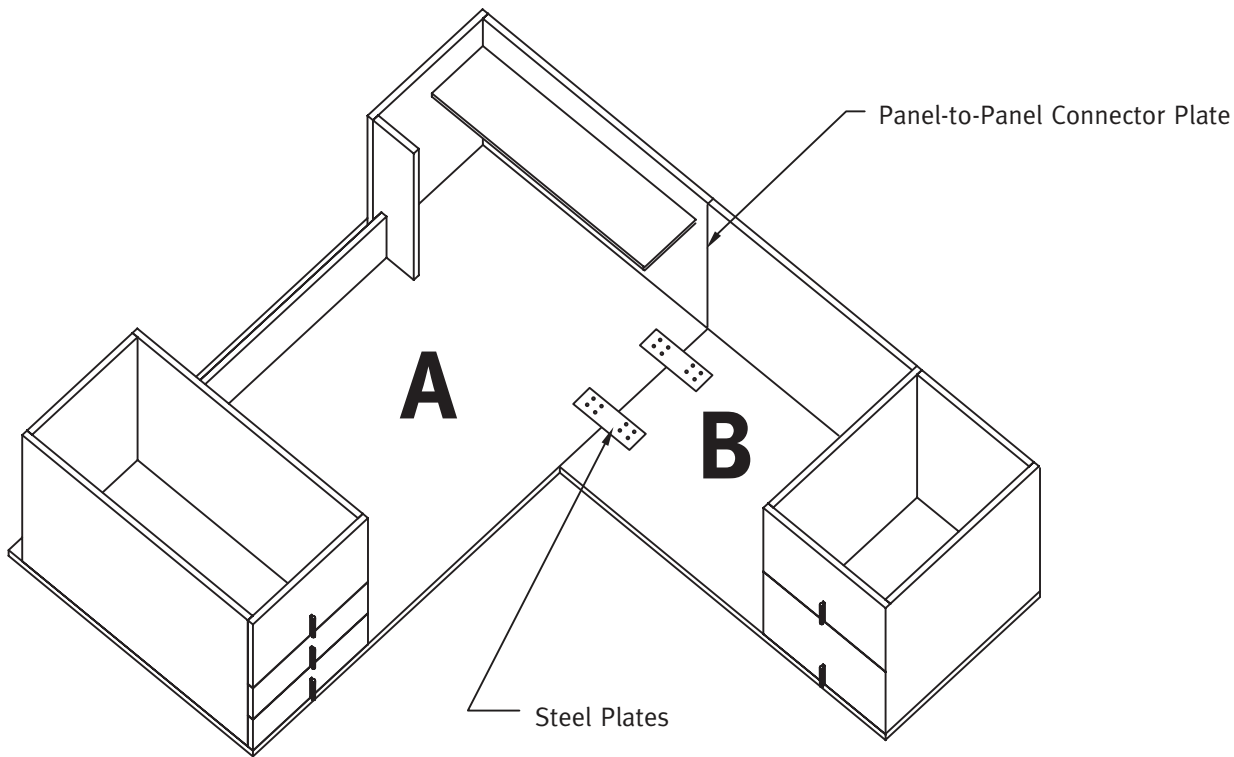

INSTRUCTIONS:

TOP CONNECTION

Included with the return will be two (2) steel plates and sixteen (16) 3/4" screws.

1. Position each plate along the bottom of desk top (unit A) so it is protruding halfway from under the top. Attach using four (4) screws each. **Do not tighten completely.**
2. Position the return (unit B) on top of the plates and align so both tops are flush at the side. Secure plates to return with four (4) screws each. **Do not tighten completely.**

VERTICAL PANEL CONNECTION

Depending on the desk type, one of the following will be included with screws with the return:

Angle Bracket: Position angle bracket where the return modesty panel and desk wing panel meet (see illustration). Secure to both return and desk.

Panel-to-Panel Connector Plate: Install the connector plate to the desk end panel just above the shelf. Align the return and secure plate to return.

Screws only: When tops are aligned, the return modesty overlaps with the desk end panel. Secure modesty to panel with screws.

LEVEL UNITS

Level both units by adjusting the floor levelers. Afterwards, tighten screws. Be careful not to apply too much pressure.

Jofco

P.O. Box 71 | Jasper, Indiana 47546 | 800-23-JOFCO | www.jofco.com

Instruction Sheet Number: IF0003

Casegood L-Group Connection

Effective Date: 4-29-09 CG03

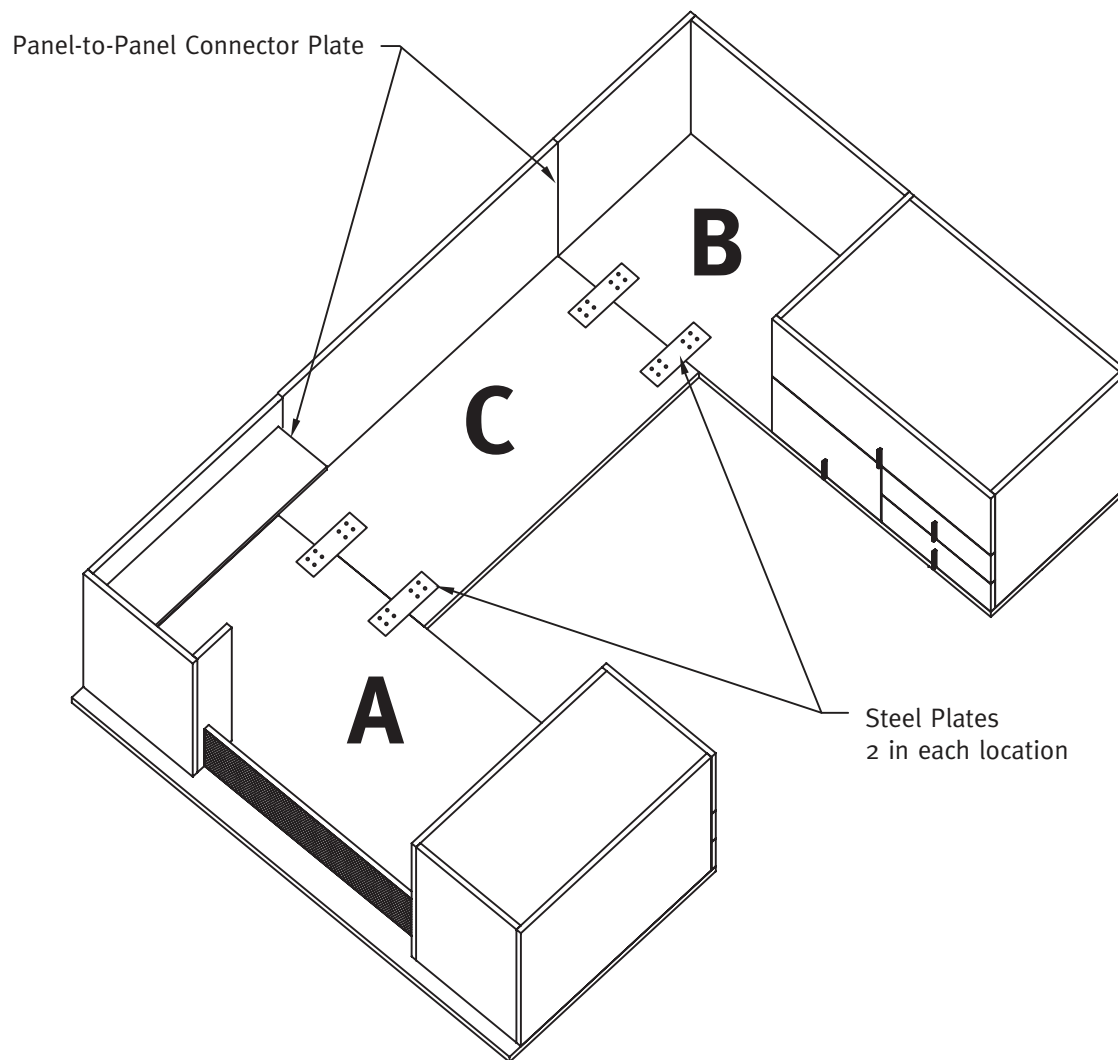

INSTRUCTIONS:

Packed with the bridge will be four (4) steel plates, 32 - 3/4" screws, and two panel-to-panel connector plates with screws. The steel plate is used on other return units, so not all screw holes will be used.

1. Place credenza (unit B) in desired location. Position a steel plate on the bottom of the credenza top so it is protruding half way from under the top. **Do not tighten completely.** Attach using four (4) screws. Repeat for the second steel plate.
2. Repeat Step 1 for the desk (unit A).
3. Uncarton the two-piece bridge (Unit C). Place the top only on the steel plates that are extending from the other units. Align to desk side for a tight fit and fasten to the plate. Check level of the desk and adjust accordingly.
4. Align and attach the other side of bridge to the credenza. Check for tight and accurate fit of the top connections before tightening screws.
5. Place modesty panel under the bridge top from the user side and align as necessary. Screw the panel-to-panel connector plate to the desk end panel just above the shelf and then to the modesty panel. Repeat for the credenza.
6. Check vertical alignment of modesty panel to both end panels. After leveling, tighten screws. Be careful not to apply too much pressure.

Jofco

P.O. Box 71 | Jasper, Indiana 47546 | 800-23-JOFCO | www.jofco.com

Instruction Sheet Number: IF00004

Casegood U-Group Connection

Effective Date: 4-29-09 CG04

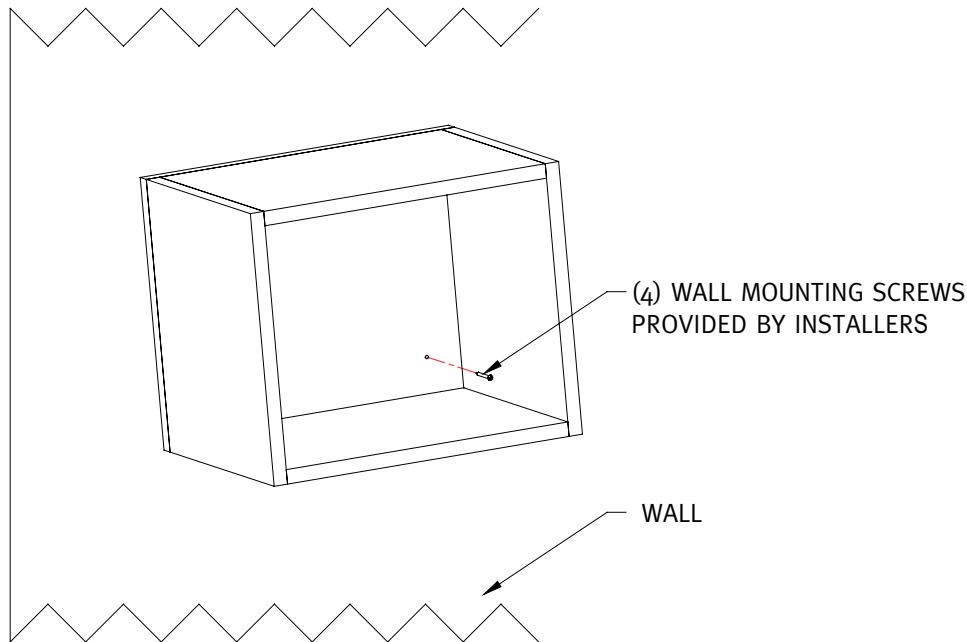
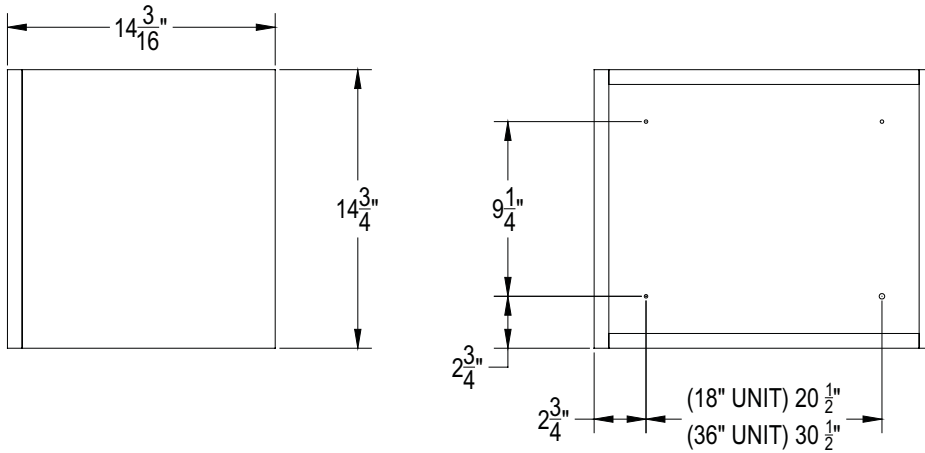

RECOMMENDED HARDWARE:
 1. Toggler brand toggle bolt anchor
 (Installer provides hardware)

- INSTRUCTIONS:**
1. Locate the first hole for the toggle bolt anchor.
 2. Locate the second hole using selected unit dimension.
 3. Locate third and fourth holes using 9-1/4" from center of first and second hole locations.
 4. Verify that holes are located correctly.
 5. Drill hole using Toggler recommendations.
 6. Install toggle bolt anchor using Toggler recommendations.
 7. Mount unit.

Jofco

P.O. Box 71 | Jasper, Indiana 47546 | 800-23-JOFCO | www.jofco.com

Installation Sheet Number: IF58001

Installation of Binder Bins

Effective Date: 2-20-07 CG01